



Front Load Washers

AFN50FSP301AW01
Front Control



www.speedqueen.com

Front Load Washer

Specifications

Model	AFN50F 
Appearance	
Color: White	✓
.09 cubic meters (3.3 cu.ft.)	✓
Stainless Steel Washtub	
3 Stainless Steel Baffles	✓
Stainless Steel Outer Draintub	✓
39.37 cm (15 1/2") Door Opening	✓
25.4 cm (10") Stainless Steel Hinge	✓
Galvanized Steel Cabinet	✓
Front Controls	✓

Technical Information	
Tub Volume - cubic meters (cu. ft.)*	.09 (3.3)
Overall Dimensions - H x W x D - cm (in)	105.1 x 68.3 x 71.12 (41 3/8" x 26 7/8" x 28")
Work Surface Height - cm (in)	105.1 (41 3/8")
Approximate Shipping Weight - kg (lb)	118 (260)
Electrical Requirements	240V/50 HzAC
Breaker Size	10 Amp
Full Load Amps	6 Amps
Motor HP	1
Spin Speeds - RPM	500, 650, 1000

Performance/Features	
Fill Hoses Included	✓
300 G-Force High Speed Water Extraction	✓
Variable Speed Induction Motor	✓
5,499 Cylinder Holes	✓
Tuff Guard Coated Top	✓
Extra Rinse Option	✓
Cycle Indicator Light	✓
Three Compartment Solution Dispenser	✓

Wash Cycles	
Cycles	8
Average Water Consumption - Liters (Gallons)	52.62 (13.9)
Agency Approvals	SAA

* Based on IEC Rating.

For the most accurate information, the installation guide should be used for all design and construction purposes. Due to continuous product improvements, design and specifications are subject to change without notice.

The quality management systems of Alliance Laundry Systems' Ripon facility has been registered to ISO 9001:2000.

Printed in the USA.

©Copyright 2010 Alliance Laundry Systems LLC

AFN50F (Shown on front)
8 Cycles, ADA Compliant, ENERGY STAR® Qualified, Front Control

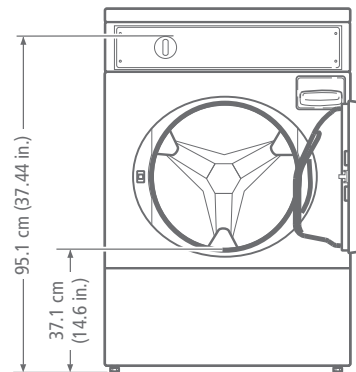
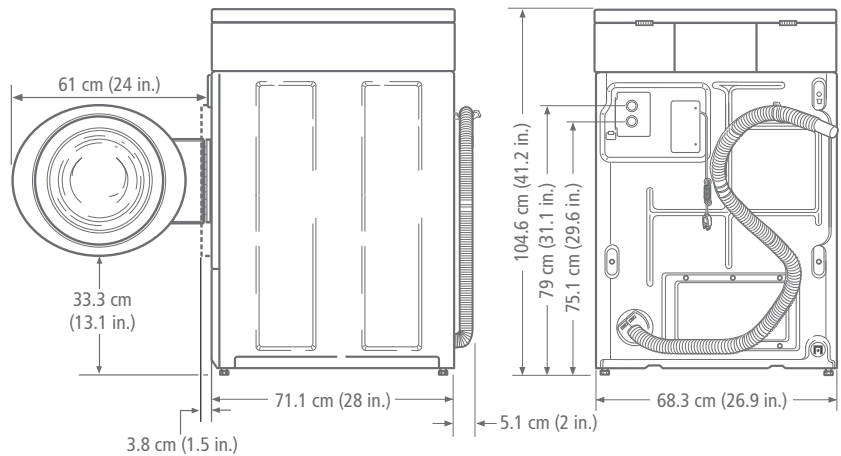
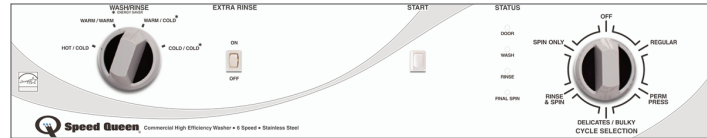

FLW2245N

CONTACT:

Speed Queen Equipment Sales

Phone 03 9495 1300

Fax 03 9495 1600

Email sales@speedqueensales.com.au

Web www.speedqueensales.com.au



AI10-0607