



PROVEN PERFORMER

Compact Commercial Laundry

LTEE5A (stack washer/dryer - electric)

LTGE5A (stack washer/dryer - gas)

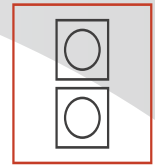

STACK UNIT

Stack washer/dryer features (White cabinet)

- Large 10kg- 304 grade stainless steel wash tub and commercial 304 grade outer bowl. To maintain the legendary Speed Queen Durability and results.
- Improved suspension with new out-of-balance logic manages and redistributes unbalanced loads for uninterrupted wash cycles
- Water use is trimmed to as low as 45 litres per cycle to reduce operating costs
- High spin speed up to 1,200 rpm (Industry leading 440 G-force) removes more water from clothes, speeding up drying cycles and lowering energy usage
- Safety Door Lock with quick access upon cycle completion
- Efficient dryer heating with 21 MJ (gas models) and up to 4,000 Watts (electric models)
- Large, easy-to-clean lint compartment - (Front of unit)
- 1913.8 sq. cm door opening is the largest in the industry, providing easy loading and unloading

Options:

- Optional venting positions for dryer exhaust
- Optional drying rack, Part No. D512082,
- Optional LPG dryer (Gas unit) conversion
- Optional 90 deg fitting inlet hoses
- Optional longer inlet hoses .



LOW ENERGY CONSUMPTION



LARGE DOOR OPENING

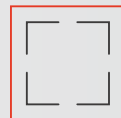

COMPACT DESIGN



LOW WATER CONSUMPTION



STAINLESS STEEL WASHER DRUM



Centralised Dual Controls

Stack washer/dryer Electronic Control

The Electronic Control keeps users informed throughout the wash process with cycle status lights and a digital cycle countdown.

Users also have the flexibility to control temperature, spin speeds, and soil levels, as well as the option of a pre-wash and/or additional rinse to achieve high levels of efficiency.

Automatic (moisture sensing) cycles come standard.



LTEE5A, LTGE5A

	LTEE5A (Electric)		LTGE5A (Gas)	
	Stack Washer	Stack Dryer	Stack Washer	Stack Dryer
Type	Stack Washer	Stack Dryer	Stack Washer	Stack Dryer
Control	Electronic	Electronic	Electronic	Electronic
Control location	Front	Front	Front	Front
Drum				
Capacity kg	10 kg	10 kg	10 kg	10 kg
Cylinder volume litres	96.8 Lt	198 Lt	96.8 Lt	198 Lt
Drum speed				
Spin speed G-Force	440	n/a	440	n/a
Spin speed rpm	1200	n/a	1200	n/a
Motor				
Motor size kW	Variable speed induction 0.67	0.25	Variable speed induction 0.67	0.25
Cabinet				
Cylinder finish	304 Grade Stainless steel	Galvinised drum	304 Grade Stainless steel	Galvinised drum
Colours	White	White	White	White
Door type (solid/window)	Window	Solid White	Window	Solid White
Heating				
Heat sources	n/a	Electric	n/a	Gas
Heating element (Electric W)	n/a	4000	n/a	n/a
Connection				
Gas inlet connection mm	n/a	n/a	n/a	9.5
Gas consumption MJ/Hr	n/a	n/a	n/a	21.09 MJ
Exhaust outlet dia. mm	n/a	102	n/a	102
Exhaust airflow litres/sec	n/a	85	n/a	85
Water temperatures	3	n/a	3	n/a
Operation				
Cycles	Heavy Duty(Default) 45min adjustable, Normal Eco, Perm Press, Delicate, Rinse and Spin, Spin Only	Dryer: Regular, Perm Press, Delicate, Time Dry, Quick Dry, Fluff Up	Heavy Duty(Default) 45min adjustable, Normal Eco, Perm Press, Delicate, Rinse and Spin, Spin Only	Dryer: Regular, Perm Press, Delicate, Time Dry, Quick Dry, Fluff Up
Water consumption per cycle litres	44.3	n/a	44.3	n/a
Water pressure kPa	140/830 kPa	n/a	140/830 kPa	n/a
Cycle indicator lights	Digital display	Digital display	Digital display	Digital display
Power				
Electrical requirements (voltage/Hz/Ph)	240/50/1, 6 amp	240/50/1, 20 amp	240/50/1, 6 amp	240/50/1 4 amp
Transport data				
Net weight / Shipping weight kg	177 / 193 (combined) -		177 / 193 (combined)	
Dimensions H×W×D mm	1986×683×704		1986×683×704	
Packing dimensions H×W×D mm	2032×737×832		2032×737×832	
Agency approvals				
Available agency approvals	Electric SAA		Electric SAA, Gas AGA #4946	

All measurements are in mm. *With levelling legs turned into base.

It is recommended that you request a full Installation & Use & Care Guide for reference and to maximise your equipments

performance and operational life. Failure to correctly install and connect these units may effectively void any manufacturer offered warranties.



Dimensions

Stack Washer/Dryer – electric

	A	B	C	D	E	F	G	H	I	J	K	L	M	N	O	P	Q
LTEE5A	1678*	1447*	597	213	610	203	391	938*	368*	813*	683	1184*	1986*	52	704	38	333*

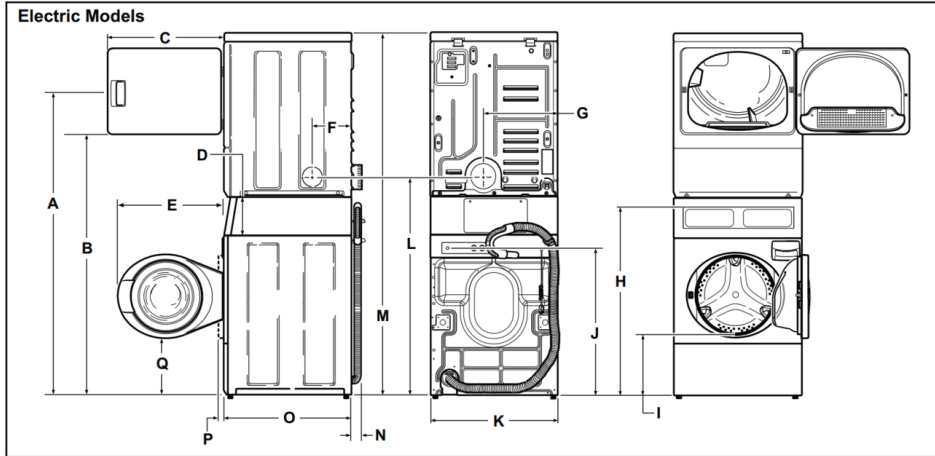

Stack Washer/Dryer – gas

	A	B	C	D	E	F	G	H	I	J	K	L	M	N	O	P	Q	R
LTGE5A	1678*	1447*	597	213	610	203	391	59	938*	368*	1140*	813*	683	1184*	1986*	52	704	38

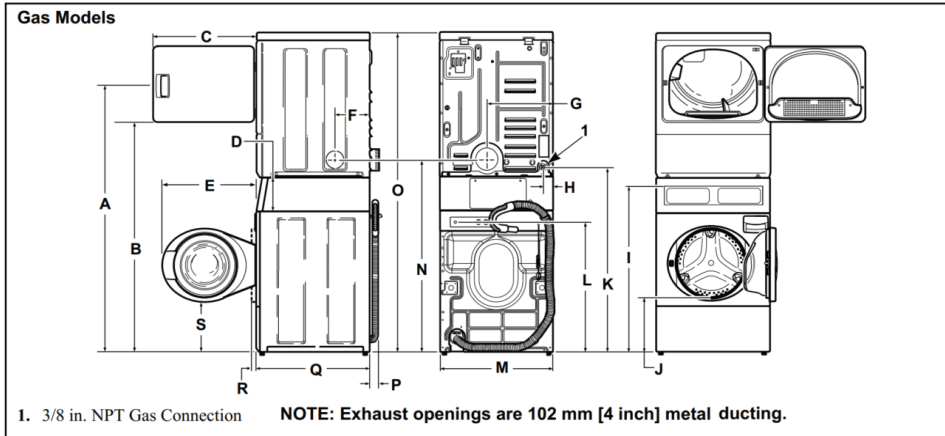

All measurements are in mm. *With levelling legs turned into base.

NOTE: Exhaust openings are 102 mm metal ducting.





Speed Queen Equipment Sale.
26 Theobald Street, Thornbury, Vic 3071
Ph: (03) 9495 1300
Fax: (03) 9495 1600
W: www.speedqueensales.com.au
E: sales@speedqueensales.com.au
Servicing Victoria, Tasmania.

The content of this brochure (including, without limitation, any analysis forming part of it) is general information, for personal use only and should not be relied upon for investment purposes. This brochure provides information based on subjective assumptions and does not provide actual or expected returns, which may in practice be lower than those stated in the brochure. You should obtain independent financial advice prior to making any decision to invest in, or with, Alliance Laundry Systems LLC. To the extent permitted by law, we do not accept any liability (whether in contract, tort, negligence or otherwise and howsoever arising), nor owe any duty of care to you, for any consequences of your acting (or refraining from acting) in reliance on the contents of this brochure. If you enter into a contract with us, we will require that you irrevocably waive your rights to bring a claim against us for acting in reliance on the content of this brochure. E&OE