

Vend Stack Washer - Dryer

STENXA (stack washer/dryer - electric)
STGNXA (stack washer/dryer - gas)

Stack Washer-Dryer features

- Improved suspension with new out-of-balance logic manages and redistributes unbalanced loads for uninterrupted wash cycles.
- Water use as low as 44.3 litres per cycle to reduce operating costs
- Extended Tumble helps eliminate wrinkling by tumbling for two minutes at 20 minute intervals if the dryer door isn't opened
- Just like their stand-alone counterparts, Speed Queen stacks are 100 percent front serviceable to limit downtime for easy service access

Control

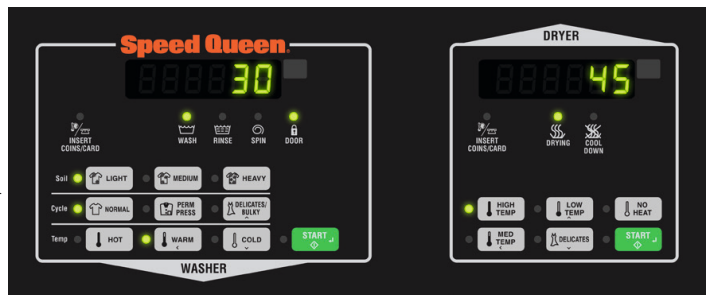

Quantum™ Gold

- In addition to its network capabilities with our larger equipment and off-site management features, Quantum Gold offers additional owner and customer benefits such as PC programming and machine audit capabilities, as well as time-of-day pricing, a "lucky cycle" for loyal customers and the ability to interface with store owner's card manufacturer of choice. Cycle modifier keys create additional profit opportunities for store owners.

Supporting Smart Card, Tap & Go, Mag Stripe

Multiple payment options -

Mobile payment transforms customer relationships. Your customers expect more from a modern experience. More versatility. - More convenience. Speed Queen Insights lets you meet—and exceed—their expectations with the Speed Queen app and Speed Queen Rewards. And because it's fully integrated with your Speed Queen washers and dryers.



Speed Queen app

Easy-to-use app creates best-in-class retail experience. Speed Queen Rewards - Increase store loyalty and encourage Monitor wash and dry -Customers can easily check cycle status and time remaining repeat business from their smartphone.

Notification of cycle completion

Customers can run errands and receive a notice when their cycle is finished. Less coin collecting saves time and hassle, letting you focus on running your business.

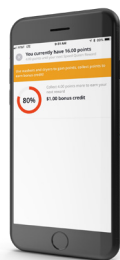

Stack Washer - Dryer

Specifications

Model	STENXA (Electric)		STGNXA (Gas)	
Type	Stack washer	Stack dryer	Stack washer	Stack Dryer
Control	Quantum	Quantum	Quantum	Quantum
Control location	Front	Front	Front	Front
Drum				
Capacity Kg	9.5	9.0	9.5	9.0
Cylinder volume litres	96.8	198	96.8	198
Drum Speed				
Spin speed G-Force	440	n/a	440	n/a
Spin speed rpm	1200	n/a	1200	n/a
Motor				
Motor size kW	Variable speed induction 0.67	0.25	Variable speed induction 0.67	0.25
Cabinet				
Cylinder finish	Stainless steel	Galvanised steel	Stainless steel	Galvanised steel
Colours	White	White	White	White
Door type (solid/window)	Window	Solid Door	Window	Solid Door
Heating				
Heat sources	n/a	Electric	n/a	Gas 27mj
Heating element (Electric W)		4600		n/a
Connection				
Gas inlet connection mm	n/a	n/a	n/a	9.5
Gas consumption BTU/Hr	n/a	25.000	n/a	25.000
Exhaust outlet dia. mm	n/a	102	n/a	102
Exhaust airflow litres/sec	n/a	50 Hz:85lt/sec	n/a	50 Hz:85lt/sec
Water temperatures	3	n/a	3	n/a
Operation				
Cycles*	Normal, Perm Press, Delicate	High, Medium, Low, Delicates, No Heat	Noram, Perm Press, Delicate	High, Medium, Low, Delicates, No Heat
Water consumption per cycle litres*	44.3	n/a	44.3	n/a
Water pressure bar	1.4/8.3	n/a	1.4/8.3	n/a
Cycle indicator lights	Yes	Yes	Yes	Yes
Power				
Electrical requirements (voltage/Hz/Ph)	240/50/1		204/50/1	
Transport data				
Net weight kg	177 (combined)		177 (combined)	
Shipping weight kg	193 (combined)		193 (combined)	
Dimensions HxWxD mm	1986x683x704		1986x683x704	
Packing dimensions HxWxD mm	2032x737x832		2032x737x832	
Agency approvals				
Avilable agency approvals	See price sheet for applicable agency approvals by market		See price sheet for applicable agency approvals by market	

*Information provided applies to premier control offered by product class.

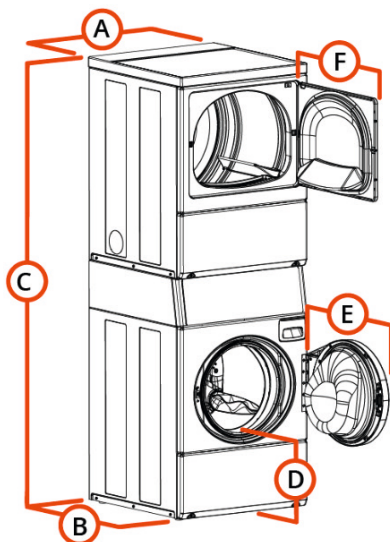

Dimensions

Model	STENXA	STGNXA
A	683	683
B	704	704
C	1986	1986
D	368	368
E	610	610
F	597	597

All measurements are in mm.

SPEED QUEEN
EQUIPMENT SALES
P: 03 94951300
E:sales@speedqueensales.com.au
www.speedqueensales.com.au